

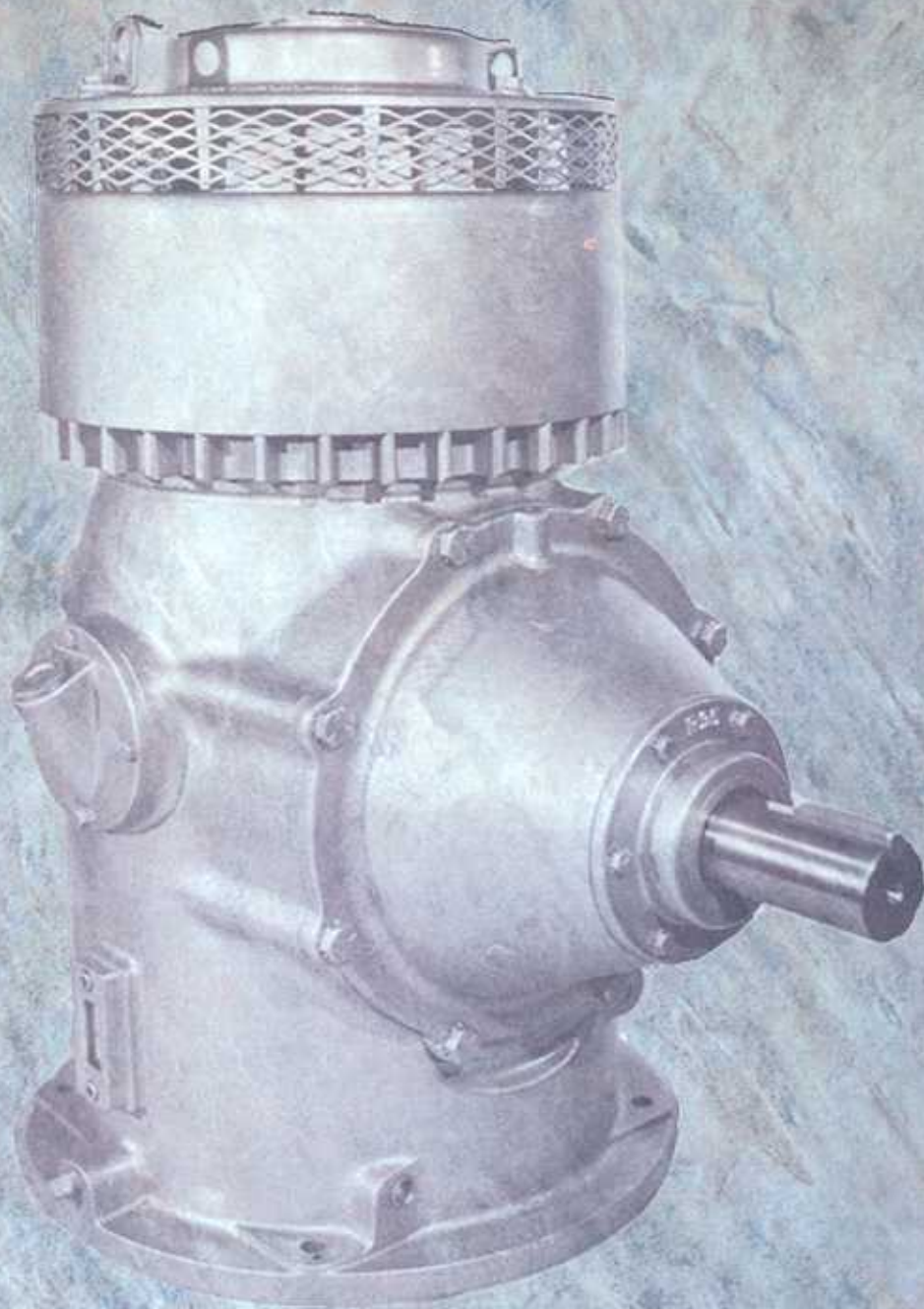

Randolph Gear Drive



Randolph Gear Drive

Product of Randolph Manufacturing Company

1110 North Avenue T / Lubbock, TX 79415

(806) 765-5583 / (888) 726-4327

FAX (806) 765-7735

Gear Drive Selection

The Following Information Should Be Supplied When Ordering Gear Drives:

Model number and ratio (input to output speed). Thrust requirements, rotation, horsepower requirements and pump head shaft size. (We define the ratio as the ratio of the horizontal input RPM to the vertical output RPM). EXAMPLE: A 2:3 ratio gear drive operating at 1760 RPM output would have 1173 RPM input.

ROTATION: Shown below are four possible rotations. Number 1 is considered standard. Unless noted differently, the drive will be manufactured to this configuration. Numbers 2, 3 and 4 are special rotations and are manufactured when specifically requested.

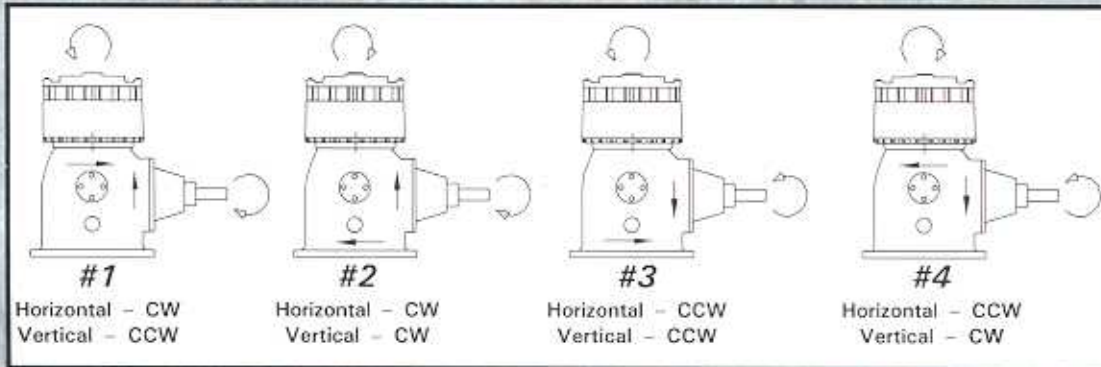

MODEL	Table 1 - Minimum Thrust Requirements For Standard Bearing Arrangement														
For the following Gear Drive (No. 1 Rotation): $Minimum\ Downthrust = \frac{Constant \times Horsepower}{Pump\ Speed}$															
Example: Model 80 - 5:6 Ratio, 72 HP, 1800 Pump Speed $\frac{19,518 \times 72}{1800} = 781\ lbs.\ Min.$															
	1:2	4:7	2:3	3:4	4:5	5:6	10:11	1:1	11:10	6:5	5:4	4:3	3:2	7:4	2:1
M40/G40 M60/G60 M80/G80 M100/G100 G125 M150	25,643	23,390	20,486	20,434	20,381	19,518	19,569	18,462	1,000	17,565	17,442	17,426	15,330	13,605	13,253
G150 M200 G200A G250 G300 G350 G400	18,638	16,386	17,424	15,558	14,502	15,224	14,907	13,130	1,000	1,000	1,000	1,000	1,000	528	1,074
G450 F500 F590 F750 F1000 F1200 F1500	NO MINIMUM DOWNTHRUST														
P200	2:1 1074	5:2 2059	3:1 3080	NO MINIMUM DOWNTHRUST											
P18AH P20A P22 P24B P30B	NO MINIMUM DOWNTHRUST														

NOTE: For rotation numbers 2, 3 and 4, contact factory. Check Table 5 for 0 down thrust on all combination, solid shaft, opposed bearings and some extra heavy thrust bearings.

Table 2 - HORSEPOWER AND THRUST BEARING RATINGS																		
Vertical RPM	340	430	580	690	720	870	960	1160	1460	1760	2000	2200	2400	2600	2800	3000	3460	3600
Percent Of HP at 1760 RPM	33	38	46	53	54	61	65	74	89	100	105	111	116	122	*128	*133	*146	*150
Percent of Thrust	170	160	145	137	135	126	122	115	106	100	96	93	90	88	86	84	82	80

To obtain horsepower and thrust bearing ratings for the speeds listed, multiply the horsepower and thrust bearing rating at 1760 RPM by the percentage in Table 2.
* Contact Factory

Standard Clutch Dimensions

"BX"	"X"	"BY"	"BZ"
3/4	3/16 x 3/32	10-32	1.375
7/8	1/4 x 1/8	10-32	1.375
1	1/4 x 1/8	10-32	1.375
1-1/16	1/4 x 1/8	10-32	1.375
1-3/16	1/4 x 1/8	1/4-20	1.750
1-1/4	1/4 x 1/8	1/4-20	1.750
1-7/16	3/8 x 3/16	1/4-20	2.125
1-1/2	3/8 x 3/16	1/4-20	2.125
1-11/16	3/8 x 3/16	1/4-20	2.500
1-3/4	3/8 x 3/16	1/4-20	2.500
1-15/16	1/2 x 1/4	1/4-20	2.500
2	1/2 x 1/4	1/4-20	2.500
2-3/16	1/2 x 1/4	3/8-16	3.250
2-1/4	1/2 x 1/4	3/8-16	3.250
2-7/16	5/8 x 5/16	3/8-16	3.250
2-1/2	5/8 x 5/16	3/8-16	3.750
2-11/16	5/8 x 5/16	3/8-16	3.750
2-3/4	5/8 x 5/16	3/8-16	3.750
2-15/16	3/4 x 3/8	3/8-16	3.750

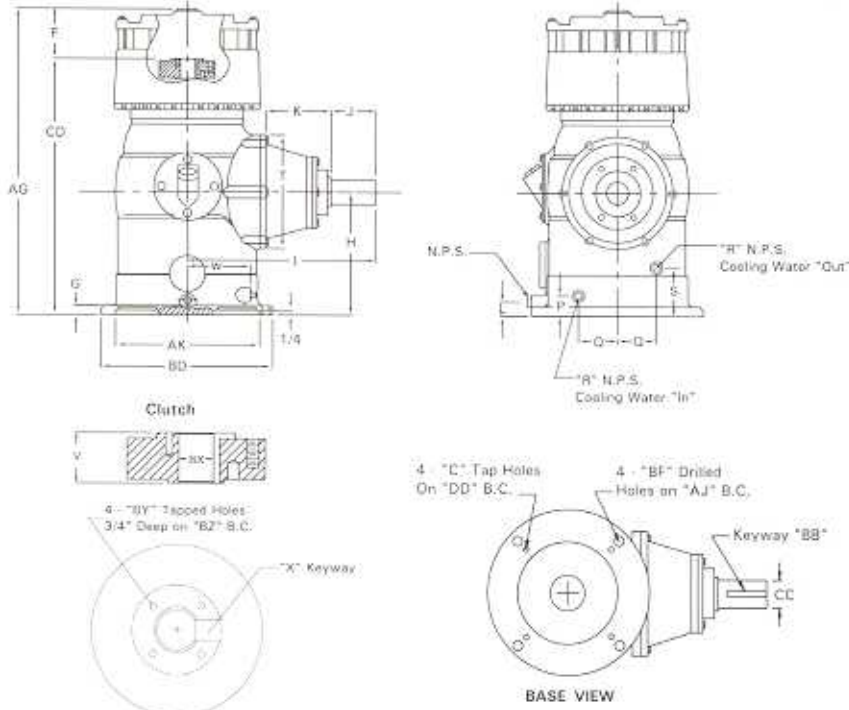

Table 3 - Dimensions

Contact factory for certified print when tolerances are required.

Model	M 40/M60 M80/M100	G40/G60 G80	G100/G125 M150	M200	G150 G200A	G250 G300	G350 G400	G450	F500/F590 F750	F1000	F1200 F1500
AG (Fan)	22-1/4	26-11/16	26-11/16	29-15/16	34	34	36	37	45-7/16	45-7/16	46-1/8
AJ	14-3/4	14-3/4	14-3/4	14-3/4	18-1/4	18-1/4	18-1/4	18-1/4	23	23	28-3/4
AK	13.501	13.501	13.501	13.501	13.501	13.501	13.501	13.501	13.501	13.501	22.005
BB	3/8 x 3/16	3/8 x 3/16	5/8 x 5/16	5/8 x 5/16	5/8 x 5/16	3/4 x 3/8	3/4 x 3/8	3/4 x 3/8	7/8 x 7/16	7/8 x 7/16	7/8 x 7/16
BD	16-1/2	16-1/2	16-1/2	16-1/2	20	20	20	20	24-1/2	24-1/2	30-1/2
BF	11/16	11/16	11/16	11/16	11/16	11/16	11/16	11/16	13/16	13/16	13/16
BX max.	1-1/2	1-1/2	1-1/2	1-15/16	1-15/16	1-15/16	2-3/16	2-3/16	2-15/16	2-15/16	4-1/4
BX min.	3/4	3/4	3/4	1-3/16	1-3/16	1-3/16	1-1/2	1-1/2	1-11/16	1-11/16	2-15/16
CCap	-	-	-	-	5/8-11	5/8-11	5/8-11	5/8-11	5/8-11	5/8-11	3/4-10
CC	1.874	1.874	2.249	2.437	2.437	2.937	2.937	2.937	3.749	3.749	3.749
CD	17-5/8	22-9/16	22-5/8	24-7/8	29-3/16	29-3/16	31-9/16	32-3/4	40-13/16	40-13/16	37-3/4
DD	-	-	-	-	14-3/4	14-3/4	14-3/4	14-3/4	14-3/4	14-3/4	26
F (Fan)	3-15/16	3-1/2	3-1/2	4-1/2	4-1/8	4-1/8	3-3/8	3-3/8	3-7/8	3-7/8	7-1/2
G	13/16	7/8	7/8	7/8	7/8	7/8	7/8	7/8	1-3/4	1-3/4	1-3/4
H	8-1/2	11-7/16	11-7/16	11-7/16	13-3/4	13-3/4	13-3/4	13-3/4	18-3/4	18-3/4	16
I	17	18	18	18	20-15/16	21-3/4	21-3/4	21-3/4	26	29	34
J (Sprag N.R.)	3-13/16	4-5/16	4-1/2	4-1/2	3-15/16	4-13/16	4-5/8	4-5/8	6-7/8	6-13/16	5
J (Pin type N.R.)	4-3/4	5	5-3/16	5-1/4	5-1/16	5-7/8	5-9/16	5-9/16	8-1/8	-	-
K (Sprag N.R.)	6-9/16	6-7/16	6-3/16	6-3/16	8-1/4	8-1/4	8-1/4	8-1/4	8-3/4	9-13/16	12-1/2
K (Pin type N.R.)	5-5/8	5-3/4	5-1/2	5-1/2	7-3/16	7-3/16	7-1/8	7-1/8	7-1/2	-	-
L	1-1/4	1-1/2	1-1/2	1-1/2	1-3/4	1-3/4	1-3/4	1-3/4	1-3/4	1-1/4	2-3/8
Mmps	1/2	1/2	1/2	1/2	1/2	1/2	1/2	1/2	1/2	1/2	1/2
N	5-5/8	9-1/8	9-1/8	9-1/8	12-3/8	12-3/8	12-3/8	12-3/8	20	20	13
O	5-3/4	5-3/4	5-3/4	5-3/4	5-3/4	5-3/4	5-3/4	5-3/4	7-1/2	7-1/2	10
P	1-3/4	1-7/8	1-7/8	1-7/8	2-1/2	2-1/2	2-1/2	2-1/2	1-1/4	1-1/4	2-1/4
Q	3-1/8	3-3/4	3-3/4	3-3/4	4-1/2	4-1/2	4-1/2	4-1/2	3-3/16	3-3/16	11-7/16
Rmps	1/2	1/2	1/2	1/2	1/2	1/2	1/2	1/2	1/2	1/2	1/2
S	4-1/2	4-5/8	4-5/8	4-5/8	5-7/8	5-7/8	5-7/8	5-7/8	1-1/4	1-1/4	2-1/4
T	9-1/4	10-3/4	10-3/4	10-3/4	15-5/8	15-5/8	15-5/8	15-5/8	22	22	20
V	2	2	2	2-1/2	2-1/2	2-1/2	3	3	4	4	5
W	5-1/4	6-1/2	6-1/2	6-1/2	7-3/4	7-3/4	7-3/4	7-3/4	12	12	8-11/16
Net Wt.	250	320	335	380	680	690	740	745	1500	1810	3000
Domestic Wt. (lbs)	275	345	360	408	718	728	778	783	1547	1857	3100
Exportwood (lbs)	340	420	435	480	820	830	880	885	1720	2030	3250
Export Cubic Ft.	9.5	9.5	9.5	10.3	17.5	17.5	17.5	17.5	38.9	38.9	55.0
Oil Cap Quarts	6	7	7	7	13	13	13	13	24	24	30

NOTE: Table is for standard gear drives only. For solid-shaft, opposed, or EHT bearings, contact factory for dimension print.



Irrigation & Industrial Pump Drives



Models designated with "M" are reduced in size
AGMA service factor of 1.5 on all models

Factory Mutual Approved
On Most Models

Ratio and Speed

Table 4 – RATIO AND INPUT SPEED (RPM)

MODEL	Output Speed (RPM)	SPEED INCREASER							SPEED DECREASER							
		1:2	4:7	2:3	3:4	4:5	5:6	10:11	1:1	11:10	6:5	5:4	4:3	3:2	7:4	2:1
M40 M60 M80 M100	1160	N/A	N/A	773	870	928	967	1040	1160	1294	1392	1450	1547	1740	N/A	N/A
	1460			973	1095	1168	1217	1309	1460	1628	1752	1825	1947	2190		
	1760			1173	1320	1408	1467	1578	1760	1963	2112	2200	2347	2640		
	2200			1467	1650	1760	1833	1972	2200	2454	2640	2750	2933	*3300		
	2600			1733	1950	2080	2167	2331	2600	2900	3120	*3250	*3467	-		
G40 G60 G80 G100 G125 M150	1160	593	659	773	870	928	967	1040	1160	1294	1392	1450	1547	1740	2017	2320
	1460	746	830	973	1095	1168	1217	1309	1460	1628	1752	1825	1947	2190	2539	2920
	1760	900	1000	1173	1320	1408	1467	1578	1760	1963	2112	2200	2347	2640	3061	*3520
	2200	1124	1250	1467	1650	1760	1833	1972	2200	2454	2640	2750	2933	*3300	-	-
	2600	1329	1477	1733	1950	2080	2167	2331	2600	2900	3120	*3250	*3467	-	-	-
	1160	N/A	N/A	N/A	870	928	967	1044	1160	1289	1392	1450	1547	N/A	N/A	N/A
1460	1095				1168	1217	1314	1460	1622	1752	1825	1947				
1760	1320				1408	1467	1584	1760	1956	2112	2200	2347				
2200	1650				1760	1833	1980	2200	2444	2640	2750	*2933				
2600	1950				2080	2167	2340	2600	*2889	*3120	*3250	*3467				
G150	1160	580	663	773	862	921	984	1041	1160	1293	1367	1461	1562	1740	2030	2275
	1460	730	834	973	1085	1159	1239	1310	1460	1627	1721	1839	1965	2190	2555	*2864
	1760	880	1006	1173	1307	1398	1493	1579	1760	1961	2074	2216	2369	*2640	*3080	*3452
	2200	1100	1257	1467	1634	1747	1867	1974	2200	2451	2593	-	-	-	-	-
	2600	1300	1486	1733	1931	2065	2206	2333	-	-	-	-	-	-	-	-
G200A G250 G300	1160	580	663	773	862	921	984	1041	1160	1293	1367	1461	1562	1740	2030	CF
	1460	730	834	973	1085	1159	1239	1310	1460	1627	1721	1839	1965	2190	2555	
	1760	880	1006	1173	1307	1398	1493	1579	1760	1961	2074	2216	2369	*2640	*3080	
	2200	1100	1257	1467	1634	1747	1867	1974	2200	2451	2593	-	-	-	-	
	2600	1300	1486	1733	1931	2065	2206	2333	-	-	-	-	-	-	-	
G350 G400	1160	N/A	N/A	773	870	928	967	1058	1160	1272	1392	1461	1562	1740	N/A	N/A
	1460			973	1095	1168	1217	1331	1460	1601	1752	1839	1965	2190		
	1760			1173	1320	1408	1467	1605	1760	1930	2112	2216	2369	*2640		
	2150			1433	1613	1720	1792	1960	2150	2358	2580	*2707	*2894	*3225		
	2500			1667	1875	-	2083	-	-	-	-	-	-	-		
G450	1160	N/A	N/A	N/A	N/A	928	967	1058	1160	1272	1392	N/A	N/A	N/A	N/A	N/A
	1460					1168	1217	1331	1460	1601	1752					
	1760					1408	1467	1605	1760	1930	2112					
	2150					1720	1792	1960	2150	2358	2580					
	2350					-	1958	2143	-	-	-					
F500 F590 F750	1160	591	672	773	870	928	967	1044	1160	1289	1392	1450	1547	1740	N/A	N/A
	1460	744	845	973	1095	1168	1217	1314	1460	1622	1752	1825	1947	2190		
	1760	897	1019	1173	1320	1408	1467	1584	1760	1956	2112	2200	2347	2640		
	1900	968	1100	1267	1425	1520	1583	1710	-	-	-	-	-	-		
	2000	1019	1158	-	1500	1600	1667	-	-	-	-	-	-	-		
F1000	720	N/A	N/A	773	N/A	N/A	600	N/A	720	N/A	864	N/A	N/A	N/A	N/A	N/A
	870			973			725		870		1044					
	1160			1173			967		1160		1392					
	1460			1267			1217		1460		1752					
	1760			-			1467		1760		2112					
F1200 F1500	720	N/A	N/A	N/A	N/A	N/A	600	N/A	720	N/A	864	N/A	CF	CF	N/A	N/A
	870						725		870		1044					
	1160						967		1160		1392					
	1460						1217		1460		1752					
	1760						1467		1760		2112					

Pin type non-reverse is standard on models M40 thru F590. Sprag type is available at extra cost.
Sprag type non-reverse is standard on F750 thru F1500.
Water-cooling coils are standard on M100, M150, M200 and G250 thru F1500.
* Contact factory when operating at this speed.

Table 5 - Horsepower & Thrust Ratings

Horsepower & Thrust Ratings			Thrust Capacity						Horsepower & Thrust Ratings			Thrust Capacity					
Model	Output Speed (RPM)	HP	Standard		Extra Heavy E.H.T.		Opposed, Solid Shaft & Combination		Model	Output Speed (RPM)	HP	Standard		Extra Heavy E.H.T.		Opposed, Solid Shaft & Combination	
			MIN	MAX	MIN	MAX	MIN	MAX				MIN	MAX	MIN	MAX	MIN	MAX
M40/G40	430	15	See Table #1	6400	See Table #1	8600	0	8400	G300	430	114	See Table #1	17600	0	26400	0	8000
	1160	30		4600		8900	0	4600		1160	222		12850	0	18975	0	5750
	1460	36		4240		6360	0	4240		1460	267		11660	0	17490	0	5300
	1760	40		4000		6000	0	4000		1760	300		11000	0	16500	0	5000
	2200	44		3720		5580	0	3720		2200	333		10230	0	15345	0	4650
	2600	49		3520		5280	0	3520		2600	366		9680	0	14520	0	4400
M60/G60	430	23	See Table #1	7200	See Table #1	9600	0	6400	G350	430	133	See Table #1	25600	0	32000	0	11200
	1160	44		5175		6900	0	4600		1160	259		18400	0	23100	0	8050
	1460	53		4770		6360	0	4240		1460	312		16960	0	21200	0	7420
	1760	60		4500		6000	0	4000		1760	350		16000	0	20000	0	7000
	2200	67		4185		5580	0	3720		2150	383		15000	0	18750	0	6583
	2600	73		3960		5280	0	3520		2500	417		14240	0	17800	0	6230
M80/G80	430	30	See Table #1	8800	See Table #1	11200	0	6400	G400	430	152	See Table #1	25600	0	32000	0	11200
	1160	59		6325		8050	0	4600		1160	296		18400	0	23000	0	8050
	1460	71		5830		7420	0	4240		1460	356		16960	0	21200	0	7420
	1760	80		5500		7000	0	4000		1760	400		16000	0	20000	0	7000
	2200	89		5115		6510	0	3720		2150	438		15000	0	18750	0	6563
	2600	98		4840		6160	0	3520		2500	476		14240	0	17800	0	6230
M100/G100	430	38	See Table #1	9920	See Table #1	13600	0	6400	G450	430	171	N/A	N/A	0	32000	0	25600
	1160	74		7130		9775	0	4600		1160	333			0	25000	0	18400
	1460	89		6572		9010	0	4240		1460	401			0	21200	0	16950
	1760	100		6200		8500	0	4000		1760	450			0	20000	0	16000
	2200	111		5766		7905	0	3720		2150	493			0	18750	0	15000
	2600	122		5456		7480	0	3520		2500	536			0	17800	0	14240
G125	430	48	See Table #1	10720	See Table #1	13600	0	6400	F500	430	190	0	32000	0	48000	0	32000
	1160	93		7705		9775	0	4800		1160	370	0	23000	0	34500	0	23000
	1460	111		7102		9010	0	4240		1460	445	0	21200	0	31800	0	21200
	1760	125		6700		8500	0	4000		1760	500	0	20000	0	30000	0	20000
	2200	139		6231		7905	0	3720		1900	513	0	19600	0	29400	0	19600
	2600	153		5896		7480	0	3520		2000	525	0	18600	0	28800	0	18600
M150	430	57	See Table #1	11520	See Table #1	14400	0	6400	F500	430	228	0	32000	0	48000	0	32000
	1160	111		8280		10350	0	4600		1160	444	0	23000	0	34500	0	23000
	1460	134		7632		9540	0	4240		1460	534	0	21200	0	31800	0	21200
	1760	150		7200		9000	0	4000		1760	600	0	20000	0	30000	0	20000
	2200	167		6696		8370	0	3720		1900	615	0	19600	0	29400	0	19600
	2600	183		6356		7920	0	3520		2000	630	0	18600	0	28800	0	18600
G150	430	57	See Table #1	12160	See Table #1	16000	0	8000	F750	430	285	0	32000	0	48000	0	32000
	1160	111		8740		11500	0	5750		1160	555	0	23000	0	34500	0	23000
	1460	134		8056		10600	0	5300		1460	668	0	21200	0	31800	0	21200
	1760	150		7600		10000	0	5000		1760	750	0	20000	0	30000	0	20000
	2200	167		7068		9300	0	4650		1900	769	0	19600	0	29400	0	19600
	2600	183		6688		8800	0	4400		2000	788	0	18600	0	28800	0	18600
M200	430	76	See Table #1	14400	N/A	N/A	0	8000	F1000	430	380	0	32000	0	48000	0	32000
	1160	148		10350			0	5750		1160	540	0	27000	0	40500	0	27000
	1460	178		9540			0	5300		1460	610	0	25200	0	37800	0	25200
	1760	200		9000			0	5000		1760	740	0	23000	0	34500	0	23000
	2200	222		8370			0	4650		1900	890	0	21200	0	31800	0	21200
	2600	244		7920			0	4400		2000	1000	0	20000	0	30000	0	20000
G200A	430	76	See Table #1	14400	See Table #1	20800	0	8000	F1200	430	456	0	40000	0	64000	0	40000
	1160	148		10350		14950	0	5750		1160	648	0	33750	0	54000	0	33750
	1460	178		9540		13780	0	5300		1460	792	0	31500	0	50400	0	31500
	1760	200		9000		13000	0	5000		1760	888	0	28750	0	46000	0	28750
	2200	222		8370		12090	0	4650		1900	1068	0	26500	0	42400	0	26500
	2600	244		7920		11440	0	4400		2000	1200	0	25000	0	40000	0	25000
G250	430	95	See Table #1	17600	See Table #1	20800	0	8000	F1500	430	570	0	40000	0	64000	0	40000
	1160	185		12650		14950	0	5750		1160	810	0	33750	0	54000	0	33750
	1460	223		11660		13780	0	5300		1460	915	0	31500	0	50400	0	31500
	1760	250		11000		13000	0	5000		1760	1110	0	28750	0	46000	0	28750
	2200	278		10230		12090	0	4650		1900	1335	0	26500	0	42400	0	26500
	2600	305		9680		11440	0	4400		2000	1500	0	25000	0	40000	0	25000

Model G200A Gear Drive

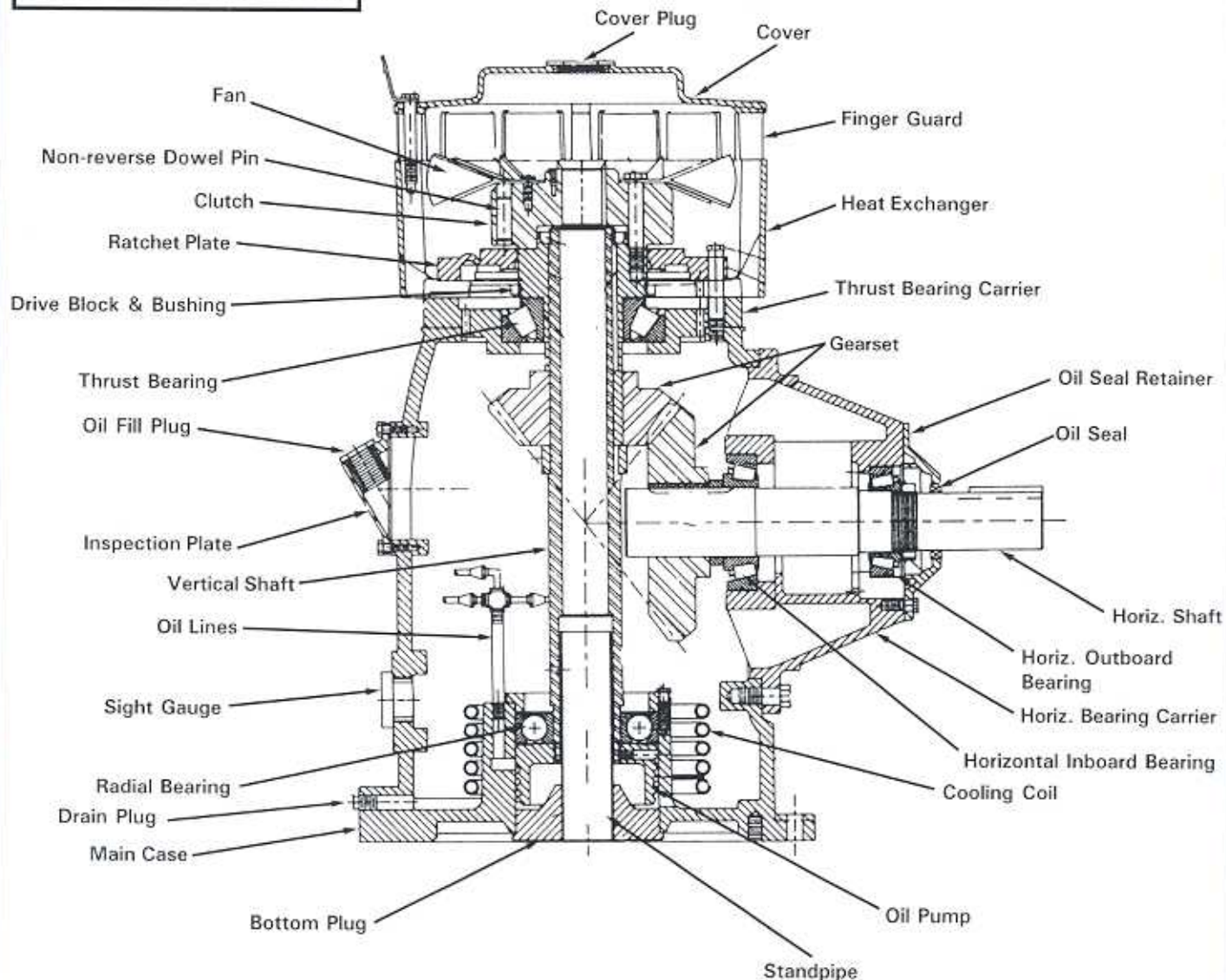

• Contact Randolph Manufacturing For All Of Your Gear Drive Repair & Part Requirements •

Typical Lubricants

AGMA Lubricant Number	3	4	5
Viscosity Range, cSt at 40°C./ISO	90-110	135-165	198-242
Max. Ambient Temperature F° / °C	40/5	80/30	140/60
ARCO	Duro 100	Duro 150	Duro 220
CITGO	Mystik JT-7 80-90	Mystik JT-7 80-90	Mystik JT-7 90-140
Conoco	Dectol 100 R & O	Dectol 150 R & O	Dectol 220 R & O
Exxon	Teresstic 100	Teresstic 150	Nuto 220
Mobil Oil	DTE Oil - Heavy	DTE Oil - Extra Heavy	DTE Oil - BB
Phillips	Magnus 100	Magnus 150	Magnus 220
Texaco	Meropa 100	Meropa 150	Meropa 220

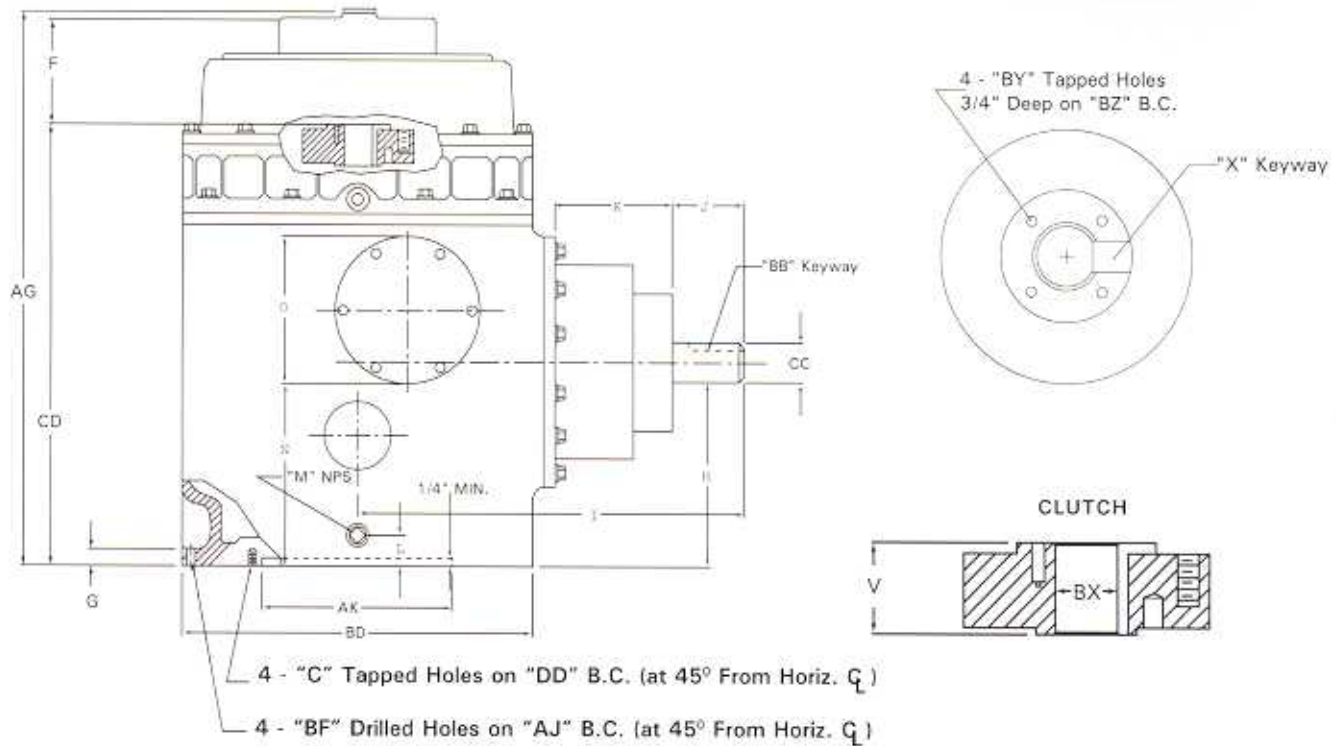

Table 6 – Dimensions Table

Contact factory for certified print when tolerances are required.
 All "P" models are fan-cooled only.

Model	P200	P16AH	P20A	P22	P24B	P30B
AG	34	25-7/8	29-3/8	38-3/8	38-3/8	46-1/8
AJ	18-1/4	14-3/4	18-1/4	23	23	28-3/4
AK	13.501	13.501	13.501	13.501	13.501	22.005
BB	5/8 x 5/16	5/8 x 5/16	5/8 x 5/16	7/8 x 7/16	7/8 x 7/16	7/8 x 7/16
BD	20	16-1/2	20	24-1/2	24-1/2	30-1/2
BF	11/16	11/16	11/16	13/16	13/16	13/16
BX max.	1-15/16	1-15/16	2-11/16	3-3/4	3-3/4	4-1/4
BX min.	1-3/16	1-3/16	1-11/16	2-1/2	2-1/2	2 15/16
Ctap	5/8-11	-	5/8-11	5/8-11	5/8-11	3/4-10
CC	2.437	2.249	2.249	3.749	3.749	3.749
CD	29-3/16	22	24-9/16	31-1/4	31-1/4	37-3/4
DD	14-3/4	-	14-3/4	14-3/4	14-3/4	26
F	4-1/8	4-7/16	4	6-1/4	6-1/4	7-1/2
G	7/8	7/8	1-1/8	1-1/4	1-1/4	1-3/4
H	13-3/4	10	12-3/8	14-1/8	14-1/8	16
I	20-15/16	20-1/4	20-3/8	30-1/2	30-1/2	37
J	3-15/16	4-3/8	4-1/4	4-3/4	4-3/4	5-1/6
K	8-1/4	6-3/4	5-1/16	11-1/8	11-1/8	12-1/2
L	1-3/4	1-1/2	1-3/4	2-1/4	2-1/4	2-3/8
Mnps	1/2	1/2	1/2	1/2	1/2	1/2
N	12-3/8	7-1/8	10	12-5/8	12-5/8	13
O	5-3/4	7-3/4	7-3/4	10	10	10
V	2-1/2	2-1/2	2-1/2	3-5/8	3-5/8	5
Net Wt.	645	520	825	1500	1500	2850
Domestic Wt. (lbs)	683	550	860	1590	1580	2960
Export (wood) (lbs)	785	650	985	1700	1700	3110
Export Cubic Ft.	17.5	14.0	13.2	28.3	28.3	40.0
Oil Cap Quarts	13	9	24	44	44	80

Standard Clutch Dimensions

"BX"	"X"	"BY"	"BZ"
1-3/16	1/4 x 1/8	1/4-20	1.750
1-1/4	1/4 x 1/8	1/4-20	1.750
1-7/16	3/8 x 3/16	1/4-20	2.125
1-1/2	3/8 x 3/16	1/4-20	2.125
1-11/16	3/8 x 3/16	1/4-20	2.500
1-3/4	3/8 x 3/16	1/4-20	2.500
1-15/16	1/2 x 1/4	1/4-20	2.500
2	1/2 x 1/4	1/4-20	2.500
2-3/16	1/2 x 1/4	3/8-16	3.250
2-1/4	1/2 x 1/4	3/8-16	3.250
2-3/8	5/8 x 5/16	3/8-16	3.250
2-7/16	5/8 x 5/16	3/8-16	3.250
2-1/2	5/8 x 5/16	3/8-16	3.250
2-5/8	5/8 x 5/16	3/8-16	3.250
2-11/16	5/8 x 5/16	3/8-16	3.750
2-3/4	5/8 x 5/16	3/8-16	3.750
2-15/16	3/4 x 3/8	3/8-16	3.750
3	3/4 x 3/8	3/8-16	3.750
3-3/16	3/4 x 3/8	3/8-16	4.250
3-1/4	3/4 x 3/8	3/8-16	4.250
3-7/16	7/8 x 7/16	3/8-16	4.750
3-1/2	7/8 x 7/16	3/8-16	4.750
3-5/8	7/8 x 7/16	3/8-16	4.750
3-11/16	3/4 x 3/8	3/8-16	4.750
3-3/4	7/8 x 7/16	3/8-16	4.750
4	1 x 1/2	3/8-16	4.750
4-1/4	1 x 1/2	3/8-16	5.000

Table 7 – Propeller Pump Drives

All models are speed deceser fan cooled only

MODEL	PUMP RPM	THRUST CAPACITY	HORSEPOWER AND ENGINE SPEED																	
			2:1		5:2		3:1		7:2		4:1		9:2		5:1		11:2		6:1	
			HP	RPM	HP	RPM	HP	RPM	HP	RPM	HP	RPM	HP	RPM	HP	RPM	HP	RPM	HP	RPM
P200	580	8600	90	1138	90	1421	75	1740												
	720	8000	110	1412	110	1764	90	2160												
	870	7500	125	1707	125	2132	110	2610												
	960	7300	135	1883	135	2352	120	2880												
P16AH	340	10000	100	880	100	858	100	1020	100	1190	80	1380	75	1530	70	1700				
	430	9800	115	880	115	1085	115	1290	115	1505	90	1720	85	1935	80	2150				
	500	8700	125	1000	125	1262	125	1500	125	1750	100	2000	95	2250	85	2500				
	580	8600	140	1160	140	1464	140	1740	140	2030	110	2320	105	2610						
	720	8000	165	1440	165	1817	165	2160	165	2520										
	870	7500	185	1740	185	2198	185	2610												
	880	7300	200	1920	200	2423														
	960	10500	180	694	180	880	170	1041	170	1190	170	1360	165	1530	135	1700	130	1836	130	2012
P20A	430	10000	200	878	200	1075	200	1317	200	1505	200	1720	205	1935	170	2150	165	2322	165	2544
	500	9500	230	1021	230	1250	230	1531	230	1750	230	2000	230	2250	185	2500	185	2700	165	3000
	580	9000	250	1185	250	1460	250	1778	250	2030	250	2320	250	2610						
	720	8500	300	1470	300	1800	300	2205	300	2520										
	870	8000	330	1775	330	2175														
	960	7500	360	1960	360	2400														
P22	340	27000	265	668	260	838	255	1020	250	1190	250	1380	240	1530	210	1700	200	1870		
	430	24000	330	845	320	1057	315	1290	310	1505	310	1720	300	1935	260	2150	260	2365		
	500	22500	375	983	365	1229	360	1500	355	1750	355	2000	340	2250	300	2500				
	580	22000	430	1140	420	1428	415	1740	410	2030	410	2320								
	720	20000	520	1415	510	1770	505	2160		2520										
	870	19000	620	1710	600	2139														
P24B	250	30000	290	491	290	615	280	750	250	875	220	1000	220	1125	220	1250	180	1375		
	340	27000	395	668	395	836	345	1020	330	1190	290	1380	290	1530	290	1700	240	1870		
	430	24000	500	845	500	1057	425	1290	410	1505	360	1720	360	1935	360	2150	300	2365		
	500	22500	580	983	580	1229	490	1500	480	1750	410	2000	400	2250	400	2500				
	580	22000	650	1140	650	1426	560	1740	505	2030	470	2320								
	720	20000	785	1415	765	1770	675	2160	595	2520										
P30B	870	19000	900	1710	900	2139														
	250	35000					390	750	375	875	365	1000	350	1125			300	1375		
	340	33000					515	1020	500	1190	485	1380	475	1530			425	1870		
	430	31000					635	1290	615	1505	600	1720	600	1935			560	2365		
	500	29000					725	1500	705	1750	686	2000	686	2250						
	580	28000					830	1740	805	2030	760	2320								
720	26000					1005	2160	975	2520											

- * Contact factory for availability of ratios not listed
- * Cooling coils are not required on above models

Model P20A Gear Drive

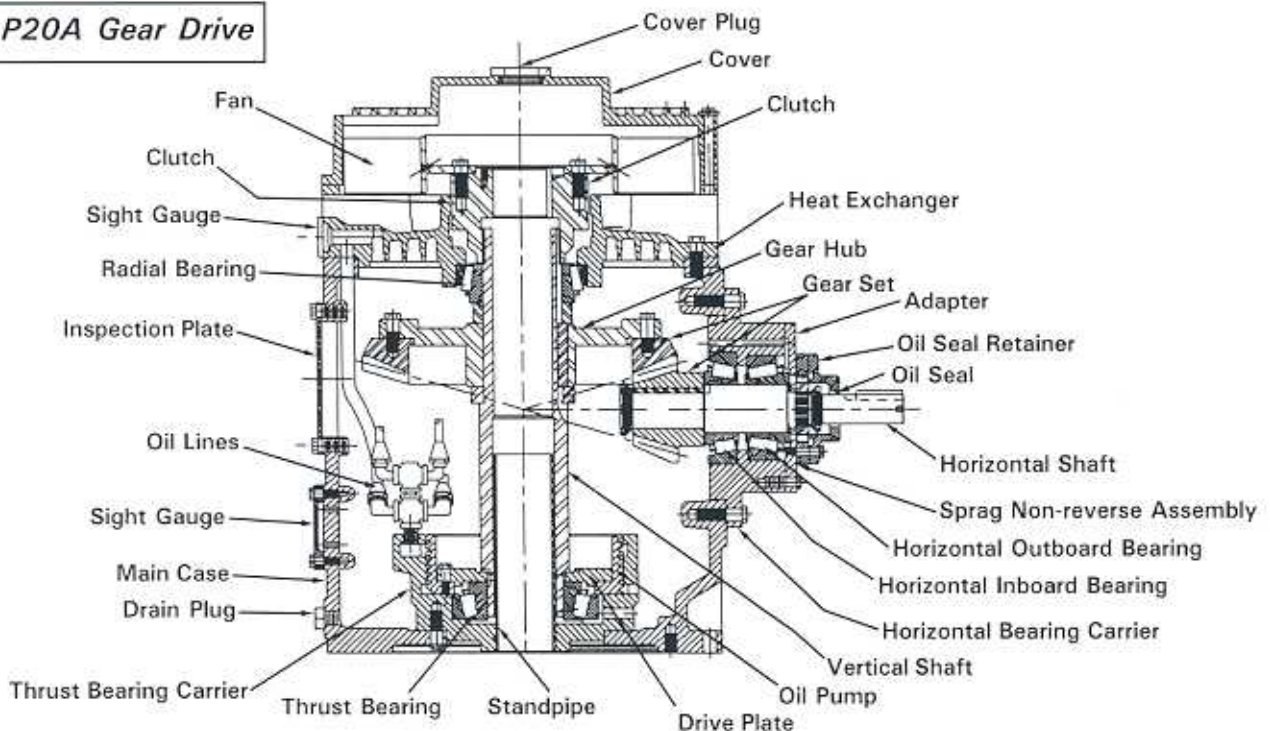

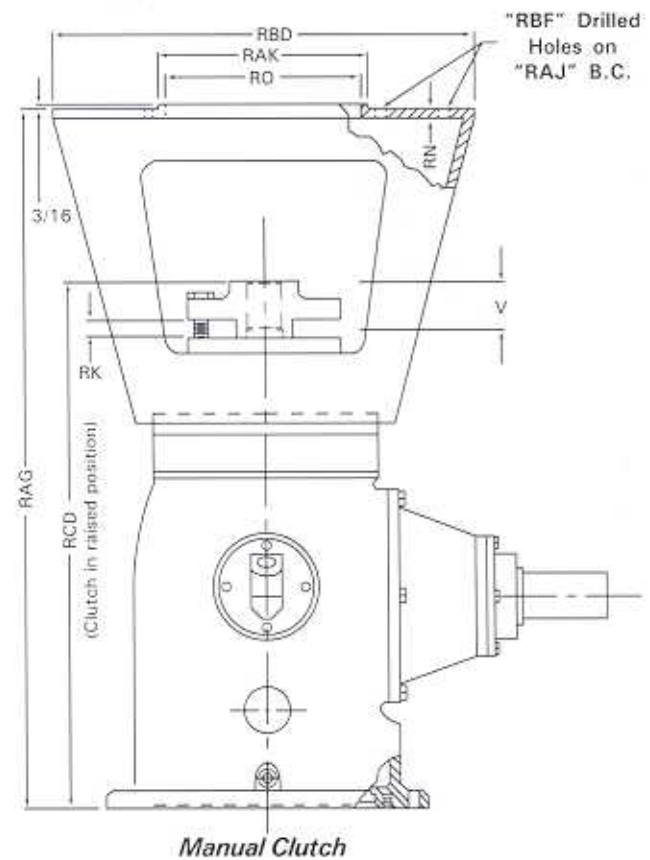
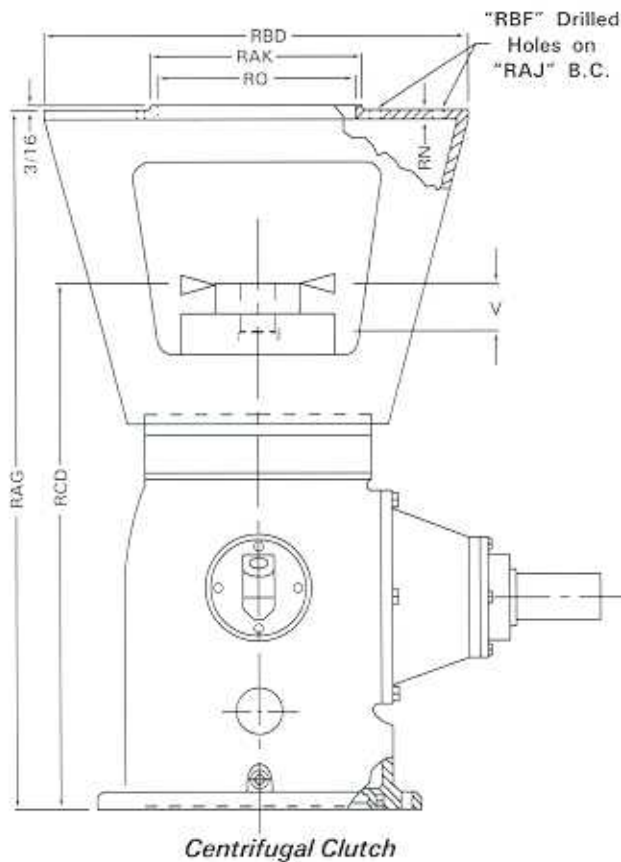

Table 8 – Dimensions Combination Drives

All combination drives have water cooling coils where required.
 All model numbers have a suffix "MS" & "TYPE" – Example: G125 MS Cent.

Model	M 40/60 M80/100	G40/60 G80	G100 G125	M150	M200	G150 G200A	G250	G300	G350 G400	F500/590 F750	P200	P20A
V	2	2	2	2	2-1/2	2-1/2	2-1/2	2-1/2	2-1/2	3	2 1/2	3
RCD Centrifugal	25-1/16	29-1/2	29-1/2	29-1/2	N/A	38	38	N/A	N/A	N/A	N/A	N/A
RCD Manual	23	27-1/2	27-1/2	27-1/2	31-1/8	33-9/16	33-9/16	33-9/16	35-1/4	45-3/8	33-9/16	31-1/2
RAG	33-1/2	38	38	38	38-9/16	45-9/16	45-9/16	45-9/16	45-3/8	59-3/4	45-9/16	43-5/8
RK Manual	7/8	7/8	7/8	7/8	1-1/16	1-1/16	1-1/16	1-1/16	1-1/16	1	1-1/16	1
RBD	16-1/2	20	20	20	20	24-7/16	24-7/16	24-7/16	24-7/16	24-1/2	24-7/16	24-1/2
RAJ	14-3/4	14-3/4	14-3/4	14-3/4	14-3/4	14-3/4	14-3/4	14-3/4	14-3/4	14 3/4 & 23	14-3/4	14 3/4 & 23
RBF	4-11/16	8-11/16	8-11/16	8-11/16	8-11/16	8-11/16	8-11/16	8-11/16	8-11/16	8-13/16	8-11/16	8-13/16
RAK	13.499	13.499	13.499	13.499	13.499	13.499	13.499	13.499	13.499	13.498	13.499	13.498
RO	12-3/4	12-3/4	12-3/4	12-3/4	12-3/4	12-13/16	12-13/16	12-13/16	12-13/16	12-1/4	12-13/16	12-1/4
RN	5/8	3/4	3/4	3/4	3/4	7/16	7/16	7/16	7/16	5/8	7/16	5/8
Appx. Net Wt. (lbs)	430	575	590	590	750	1010	1010	1010	1090	1600	865	1050
Domestic Wt. (lbs)	460	605	620	820	780	1045	1045	1045	1125	1675	900	1090
Export Wt. (lbs)	545	712	727	727	900	1230	1230	1230	1310	1865	1085	1195
Export Cube Ft.	10.7	13.0	13.0	13.0	13.9	34.0	34.0	34.0	34.0	57.0	34.0	19.0

All other dimensions and oil capacity are the same as standard gear drive.
 All models are standard sprag type non-reverse except centrifugal, which has no non-reverse protection.
 Contact factory for vertical speeds other than 1760 rpm.

The Original Fan-Cooled Gear Drive

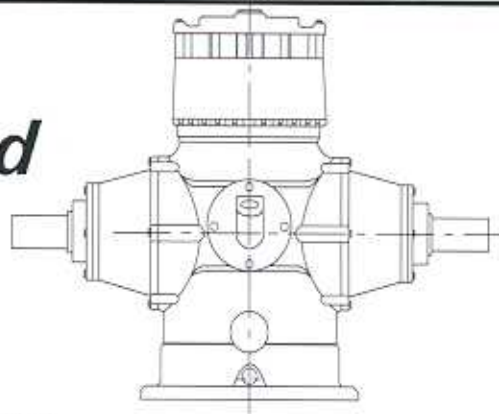

Randolph Right Angle Dual Drive

This drive may be used as a Double Engine Drive or as a Combination Drive using a horizontal electric motor and engine. When used as a Combination Drive, over-running clutches should be provided for disengaging the idle driver. When used as a Dual Drive with the two input loads equal, the transmission capacity is 150% of the standard rating of the G40 through G200A only. Contact the factory for the maximum rating of the G250 through G400.

Fan Cooled Gear Drives

Our air cooled heat exchanger was designed to meet a need in areas where cooling water and ambient temperatures create a problem when cooling coils were the only way to cool the oil in a gear drive. The Models M40 thru M80 and G40 thru G200A, with fan cooling only, should require no other means of cooling. The Models M100, M200 and G250 thru F1500 have cooling coils included and must be connected for any extended use or high ambient conditions. All propeller pump drives require no water cooling. Oil temperatures of 200°F (93C) are not dangerous. Best temperatures would range between 135°F (57C) and 180°F (82C).

Gear Drive Construction

High tensile strength castings are used throughout for rigidity. An outstanding feature of Randolph Gear Drive is anti-friction ball or taper bearings, which are engineered for long life and rugged service. There is a large oil level sight gauge glass on all drives. The air cooled heat exchanger, for control of oil temperature rise, eliminates clogged cooling coils, expensive cooling water hook-ups, and the use of undesirable types of cooling water. Alloy steel spiral bevel gears and pinions are case hardened and lapped in pairs to insure perfect contact and long life. Positive type non-reverse available on all models. Pressure type lubrication systems on all drives. (Lubrication systems are available for very low speed applications upon request). The permissible loading varies with the speed. In borderline cases, a maximum of 10% overloading is permitted before the warranty is voided. This overloading condition should be used with the knowledge that a corresponding reduction of 20% to 30% in bearing life may be expected.

Randolph Gear Drive Efficiencies

Randolph Manufacturing Company recommends a design value of 96% efficiency in all applications. The actual efficiency will depend on operating loads, speeds, temperatures and other parameters. The 96% value can be taken as a minimum value throughout the life of the unit. If unusual conditions exist, consult the factory for your specific application.

Limited Warranty

The Randolph Right Angle Gear Drive is warranted, as provided hereafter, for a period of one (1) year from the date of installation, provided installation is not more than three (3) months after date of sale, against defects in workmanship, design and material when operated under normal service at rated capacity, subject to the following conditions:

Within the above stated warranty period, the manufacturer, Randolph Manufacturing Company, 1110 N. Avenue T, Lubbock, Texas 79415, will replace defective parts and all transportation costs paid by the customer, at manufacturer's location at 1110 N. Avenue T, Lubbock, Texas 79415;

The replacement of defective parts and transportation costs as set forth in Paragraph 1 above shall be buyer's and user's sole and exclusive remedy for any and all damages or loss arising out of or caused by alleged negligence on the part of manufacturer or alleged defects in workmanship, design, warning, or material;

This limited warranty shall not apply to drives which have been the subject of abuse, neglect, accidents, misuse, improper installation, overloading rated horsepower of the drive or overloading rated capacity of thrust bearing (in this regard the thrust capacity of the drives should be verified by the pump manufacturer with whose equipment the drive is used);

This limited warranty shall not apply to bearings, accessories, machinery component parts or other articles of merchandise manufactured by persons or other entities other than Randolph Manufacturing Company.

This limited warranty is given in lieu of all others, and Randolph Manufacturing Company hereby disclaims all other warranties of any kind, including implied warranties of merchantability, implied warranties of fitness and implied warranties of fitness for a particular purpose:

This limited warranty and the exclusive remedy provided herein to buyer and user shall be construed under the laws of the state of Texas, United States of America as they exist at the time claim is made under this limited warranty.

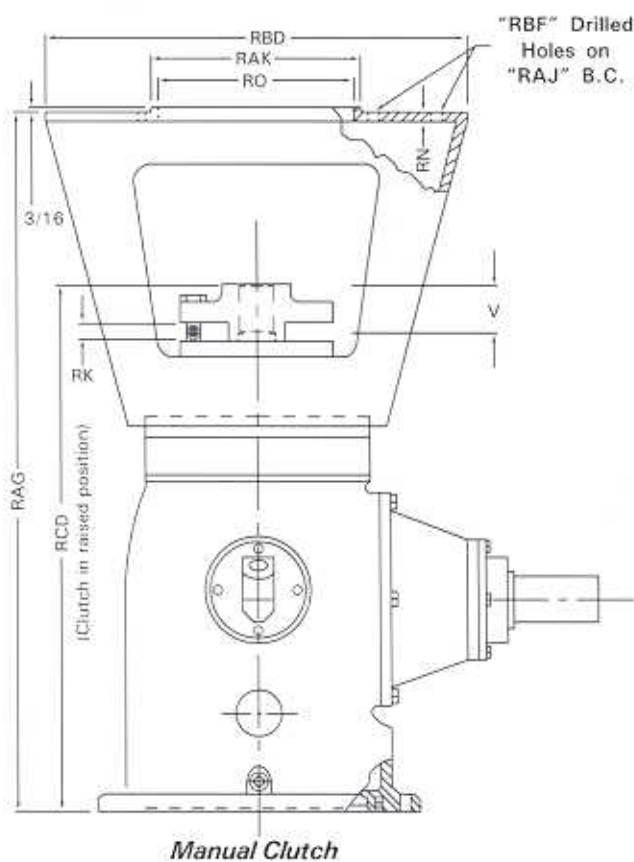
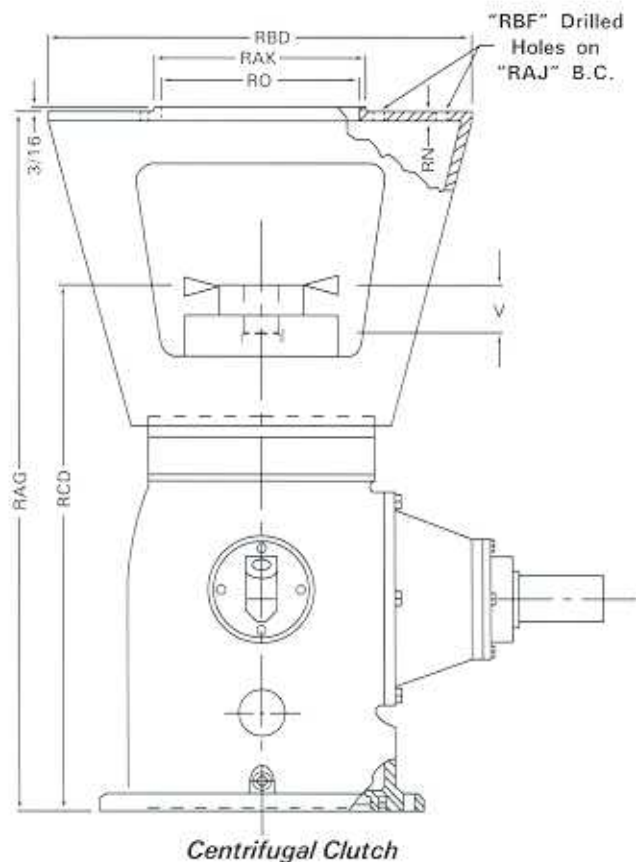

Table 8 – Dimensions Combination Drives

All combination drives have water cooling coils where required.
 All model numbers have a suffix "MS" & "TYPE" – Example: G125 MS Cent.

Model	M 40/60 M80/100	G40/60 G80	G100 G125	M150	M200	G150 G200A	G250	G300	G350 G400	F500/590 F750	P200	P20A
V	2	2	2	2	2-1/2	2-1/2	2-1/2	2-1/2	2-1/2	3	2-1/2	3
RCD Centrifugal	25-1/16	29-1/2	29-1/2	29-1/2	N/A	38	38	N/A	N/A	N/A	N/A	N/A
RCD Manual	23	27-1/2	27-1/2	27-1/2	31-1/8	33-9/16	33-9/16	33-9/16	35-1/4	45-3/8	33-9/16	31-1/2
RAG	33-1/2	38	38	38	38-9/16	45-9/16	45-9/16	45-9/16	45-3/8	59-3/4	45-9/16	43-5/8
RK Manual	7/8	7/8	7/8	7/8	1-1/16	1-1/16	1-1/16	1-1/16	1-1/16	1	1-1/16	1
RBD	16-1/2	20	20	20	20	24-7/16	24-7/16	24-7/16	24-7/16	24-1/2	24-7/16	24-1/2
RAJ	14-3/4	14-3/4	14-3/4	14-3/4	14-3/4	14-3/4	14-3/4	14-3/4	14-3/4	14 3/4 & 23	14-3/4	14 3/4 & 23
RBF	4-11/16	8-11/16	8-11/16	8-11/16	8-11/16	8-11/16	8-11/16	8-11/16	8-11/16	8-13/16	8-11/16	8-13/16
RAK	13.499	13.499	13.499	13.499	13.499	13.499	13.499	13.499	13.499	13.498	13.499	13.498
RO	12-3/4	12-3/4	12-3/4	12-3/4	12-3/4	12-13/16	12-13/16	12-13/16	12-13/16	12-1/4	12-13/16	12-1/4
RN	5/8	3/4	3/4	3/4	3/4	7/16	7/16	7/16	7/16	5/8	7/16	5/8
Appx. Net Wt. (lbs)	430	575	590	590	750	1010	1010	1010	1090	1600	865	1050
Domestic Wt. (lbs)	460	605	620	620	780	1045	1045	1045	1125	1675	900	1090
Export Wt. (lbs)	545	712	727	727	900	1230	1230	1230	1310	1865	1085	1195
Export Cube Ft.	10.7	13.0	13.0	13.0	13.9	34.0	34.0	34.0	34.0	57.0	34.0	19.0

All other dimensions and oil capacity are the same as standard gear drive.
 All models are standard sprag type non-reverse except centrifugal, which has no non-reverse protection.
 Contact factory for vertical speeds other than 1760 rpm.

Randolph Gear Drive

Product of Randolph Manufacturing Company

1110 North Avenue T / Lubbock, TX 79415

(806) 765-5583 / (888) 726-4327

FAX (806) 765-7735